

SHINSUNG

SF6 GAS INSULATED

Pole Mounted VIT LBS/Sectionalizer



SPGAS SERIES
15kV, 27kV, 38kV
400A, 630A

Ratings & Specifications

Type of Products	SPG-15-6	SPGAS-26-A	SPGAS-36-A
Basic Ratings			
Maximum System Voltage	15 kV	27 kV	38 kV
Rated Continuous Current	630 A	630 A	630 A
Rated Frequency	50/60 Hz	50/60 Hz	50/60 Hz
Short Time Withstand Current (rms)	25kA/1sec	16kA/1sec	25kA/1sec
Making and Breaking Capacity			
Mainly Active Load Current	630A	630A	630A
Number of Load-break Operations	400 times	400 times	400 times
Short-circuit Making Current (peak)	41.6 kAp	40kAp	32.5 kAp
Number of Making Operations	5 times	5 times	5 times
Cable Charging Current	10A	25A (200 A)	20 A
Line Charging Current	10A	1.5A	2A
Closed Loop Circuit Current	630 A	630 A	630 A
Transformer Magnetizing Current	22A	22A	22A
Power Frequency Withstand Current Test			
Wet Condition- 10 sec (Ph- Ph, Ph-Eth, Across Interrupters)	45 kV	50kV	70 kV
Dry Condition - 1 min (Phase to Earth, Phase to Earth)	50 kV	60kV	70 kV
Dry Condition - 1 min (Across Interrupter)	50 kV	60kV	80 kV
Impulse Withstand Current Test (1.2 x 50 μs)			
Phase to Phase, Phase to Earth	110 kV	150kV	170 kV
Across Interrupter	121 kV	150kV	195 kV
Other Ratings & Specifications			
Arc Extinction Medium	SF 6 Gas	SF 6 Gas	SF 6 Gas
Insulation Medium	SF 6 Gas	SF 6 Gas	SF 6 Gas
Operation Performance			
Closing/Opening Time	< 0.7 sec	< 0.7 sec	< 0.7 sec
Mechanical Operations (Guaranteed)	10000 times	10000 times	10000 times
Operating Temperature	-25 ~ 70° C	-25 ~ 70° C	- 25 ~ 70° C
Gas Pressure			
Nominal Pressure (kgf/cm² G, at 25°C)	0.7	0.7	0.7
Minimum Gas Pressure (kgf/cm² G)	0.1	0.1	0.1

* SPG-15-6, SPGAS-26 and SPGAS-36 have the contacts of the same material, isolating distance and structure.

* Electrical and mechanical specifications and ratings of AUTOMATIC, MANUAL Type Products are all the same if a Switch belongs to the same voltage class.

Introduction

SPGAS is 3 phase, SF₆ gas insulated load break switch (LBS) for overhead power distribution system. SPGAS series switches have been designed to meet the growing requirements for oil-less, maintenance free, long life, maximum safety and all-in-one design for application to Distribution Automation System (DAS) or SCADA System.

SPGAS series switches have been fully certified in accordance with IEC 60265-1, 60694 or their equivalent standards to meet or exceed customer specifications. SPGAS switches are suitable for operation under the following conditions.

- Ambient air temperature : -25~70 °C (MANUAL Type: -40~70 °C)
- Maximum Radiation : 1,100 W/m²
- Relative humidity: Up to 100% RH
- Wind Velocity: 160km/h
- Altitude: Up to 2500m above Sea Level
- Climatic condition: Tropical Climate
- Pollution Level: Heavy Pollution (ESDD 0.35 mg/cm²)

Prominent Features

All-in-one Design for SCADA system

- Built-in CT's and Voltage Sensors are all fitted in SPGAS switching tank. The SPGAS Switch can be easily applicable to DAS or SCADA System without any extra costs.

Oil-less, Maintenance Free

- Using SF₆ gas as an insulating and interrupting medium eliminates the necessity for maintenance.
- Compact operation mechanism assembly is located inside the thoroughly sealed tank case. Therefore, the mechanism assembly is protected from corrosion and every environmental attack.

Robustness and Long Life

- Stainless steel Tank Case with more than 3 mm thickness is designed for its maximum robustness and minimum welding line to minimize corrosion.
- The robust 'tulip' type contact made of copper-tungsten tips ensures long contact life.
- Advanced TIG welding technique on stainless steel tank and double sealing technique with EPDM rubber for bushing mounting shows 0.02% gas leakage rate per year and 2,500 years service life.
- SPGAS Switch has so robust mechanical construction that it experienced 5,000 times mechanical operation test and 10,000 times operations are guaranteed.

Quick Close/Open, Operator-independent Mechanism

- The simple toggle action spring mechanism shows operator-independent quick close, quick open operation (below 0.7 sec operation time when electrical operation).
- Driving motor is coupled with manual operating handle through the medium of one way rotating bearing, therefore, manual operation is guaranteed even though driving motor gets out of order.

Reliable Insulation and Interruption Capacity

- Experienced and mastery breaking part design including pure puffer principle makes the arcing time just half a cycle. Due to this, decomposition of SF₆ gas from the arc is negligible and the insulation capacity of SF₆ gas doesn't decrease during all service life.
- With the breaking part design, all insulation and interrupting ratings of the switch are guaranteed at atmospheric gas pressure 0.0 kgf/cm²G. (* Low gas pressure alarm : 0.1 kgf/cm²G)

- The heavy duty tulip type contacts made of copper-tungsten arc resistance material ensures 5 times making current test and 400 times load current switching test.

Safety Devices

- In the event of an internal arc fault, Safety Bursting Membrane on the rear side of the SPGAS Switch ruptures to release over-pressure gas. This eliminates the risk of explosion.
- Since SPGAS switch is not oil-filled, a major fire hazard is eliminated. In addition, two additional safety devices are available in the SPGAS switch.
Firstly, Manual Lockout provides lockout to the operating mechanism when it is pulled down to the lock position using a hook stick.
Secondly, Low Pressure Interlock or Low Pressure Sensor locks the operating mechanism or gives signal to the controller if the gas pressure in the tank drops below a pre-set value.
- SPGAS switch has passed Internal Arcing Test with 20 kA for 0.1 sec in accordance with IEC 62271-200 and Insulation Coordination Test in accordance with IEC 60071-1.

Detailed Descriptions

Bushing

- **Porcelain bushing** is standard. It is horizontally mounted to the enclosure tank. The inside bushing hole walls are treated with semi-conductive painting to shorten the gap between the copper stud and the bushing wall. This enables the switch to have good RIV characteristics and also good partial discharge control.
- Alternatively, **epoxy bushing and silicon rubber boots** are also available. Silicon rubber boots are put on the epoxy bushing to increase the voltage insulation and to protect inner bushing from external impact.

Bushing Terminal

NEMA type flat bare terminal made of copper alloy is standard for bushing terminal. According to local environments, customers can choose alternatives as following.

- Standard NEMA type flat bare terminal
- Universal Clamp Type Terminal
- Eyebolt Type Terminal

Tank Case

SUS 304 Tank Case with more than 3 mm thickness is designed for its maximum robustness. Therefore, even at a maximum bursting pressure of the tank (4-6 kgf/cm² G), switching operation is not disturbed. And its minimum welding line on stainless steel tank case result in minimum corrosion.

SF6 Gas

- The insulating medium of SPGAS Switch is SF6 gas whose quality meets the requirement of IEC60376. The leakage rate of the SF6 gas is less than 0.7×10^{-6} cc/sec; In other words, 0.02% per year.
- To maintain the insulating capacity of SF6 gas during the service life of Switch, a moisture and de-composed gas absorber is also contained in the switch tank.

Operation Mechanism

- The simple toggle action spring mechanism enables the switch to have operator-independent quick close, quick open operation. The electrical operation time is below 0.7 sec, and close/open operation can be done more than 500 times with fully charged battery.
- Driving motor is coupled with manual operating handle through one way rotating bearing, therefore, during a manual handle operation (required force: 17- 18 kg), the driving motor is actually disconnected with driving shaft. This means that manual operation is guaranteed in spite of the driving motor's trouble.

Motor Box

Driving Motor, Auxiliary Contacts, and Protection PCB are located inside the Motor Box and these devices are connected to the control unit through control cable and connector. Stainless steel Motor Box is thoroughly welded underneath the Tank Case.

Protection PCB

The CT's are connected to automatic CT shorting protection PCB installed in the Motor Box, passing through the rubber gasket sealing.

- Automatic CT shorting device protects the CT's when the CT cable is disconnected.
- This PCB also protects control circuit from electromagnetic disturbance as like surge voltage.

Interrupting Parts

- SF6 Gas provides excellent load breaking capacity, high insulating ability and invincible arc-extinguishing performance. Therefore, the arcing time is just half a cycle. Due to this extremely short arcing time, the decompositions of SF6 gas are negligible, even after duty test. And the insulation and interrupting ratings are guaranteed at atmospheric gas pressure (0.0 kgf/cm²G).
- There is no plastic insulating material between open contacts, so there is no problem caused by plastic material's deterioration by arc or leakage current.
- Unique puffer principle is applied. The compressed SF6 gas concentrates to the arc through the nozzle and then exhausts it, condensing and cooling the arc plasma.
- The robust tulip contacts comprised of nine(9) piece copper-tungsten tips have five(5) times making operation and 1000 times load current breaking capacity guaranteed (400 times tested).

CT's and Voltage Sensors

- CT's and Voltage Sensors are installed inside the tank case. CT's and Voltage Sensors are connected to control unit after passing through gas sealing and Protection PCB.
- Resistive voltage sensor has $\pm 1\%$ accuracy.

Safety Bursting Membrane

- Safety Bursting Membrane bursts at a pressure of 4- 6 kgf/cm².G and release the excessive gas pressure(caused by internal fault) to outside of the enclosure tank, before the tank or bushings are destroyed.
- The membrane is located in opposite side of the manual operating handle and sends out the excessive gas in the safe direction.
- If the bursting membrane operates, the SF6 gas is completely exhausted and Low Pressure Interlock or Low Pressure Sensor prevents any electrical and manual operation.

Manual Lockout

- If it is pulled down, it is toggle-acted, keeps the present position, mechanically locks out both close and open operation and it gives dry contact to the control.
- When it is pushed up, it releases the lockout function and gives dry contact to the control.

Low Pressure lockout and Indicator

If the pressure sensor senses low gas pressure, it activates the low pressure target and also the Low Pressure Lockout to prevent any switch operation by both electrical and mechanical methods.

Low Pressure Sensor and Optional Gas Pressure Gauge

The low pressures sensor gives a dry contact information to the control for lockout or alarm. And the gas pressure can check through the optional pressure gauge.

Optional Parts and Accessories

- Low Pressure Interlock
- Low Pressure Target
- Lightning Arrester Plate
- Gas Pressure Gauge
- Bird Guard Cap
- Operation Counter
- Eyebolt Type Bushing Terminal or Clamp Type Bushing Terminal
- Epoxy Bushing and Silicon Rubber Boots
- Mold Cone and Lead Wire
- Mounting Bracket (Cross Arm)
- Low Pressure Sensor (For Automatic Type)
- Internal Voltage Sensors (For Automatic Type)
- Ground Actuator (For Manual Type)

Dimension & Part Names – Automatic Type

27kV LBS Layout

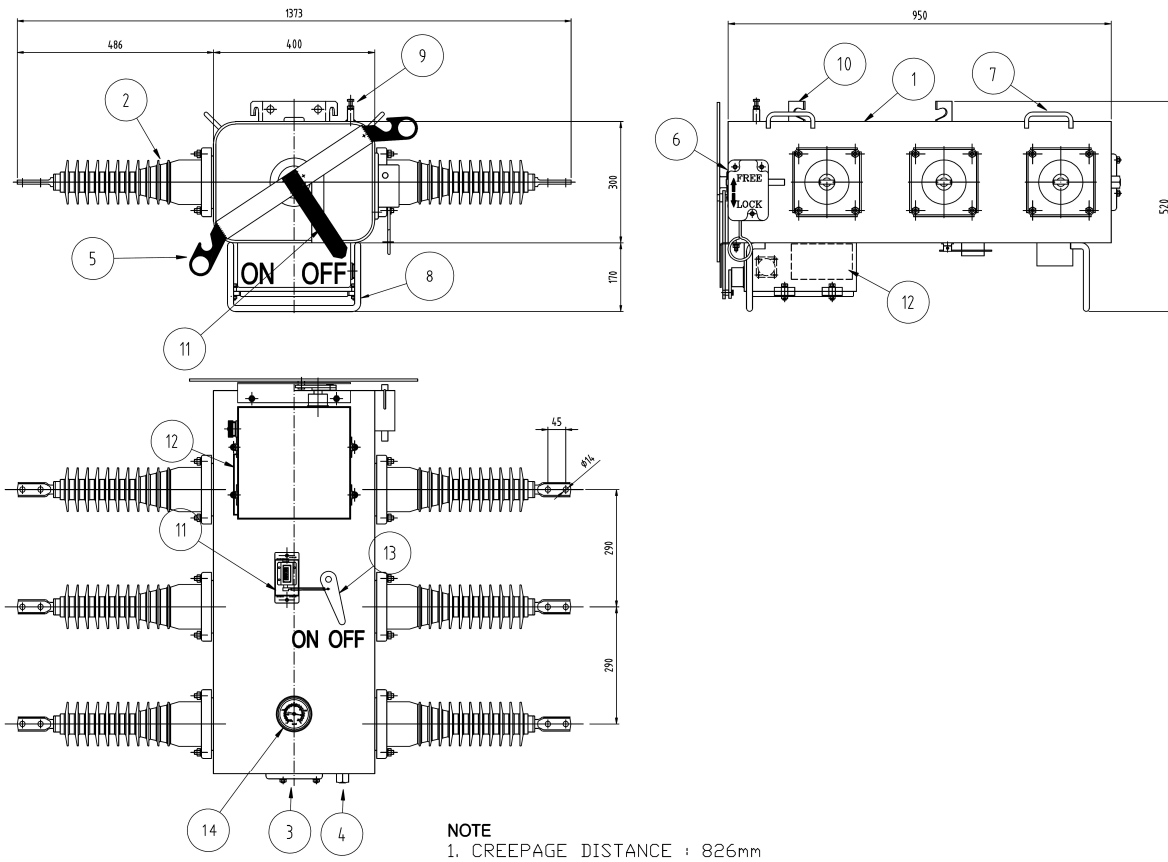

No.	Name of Parts
1	Tank
2	Epoxy Silicone Rubber Bushings
3	Safety bursting membrane
4	Gas filling Valve
5	Operating Handle
6	Manual Locking Device
7	Lifting Lugs
8	Legs
9	Earthing Terminal
10	Mounting hangers
11	Operation counter
12	Name Plate
13	On/Off Indicator
14	Gas pressure Gauge

38kV LBS Layout

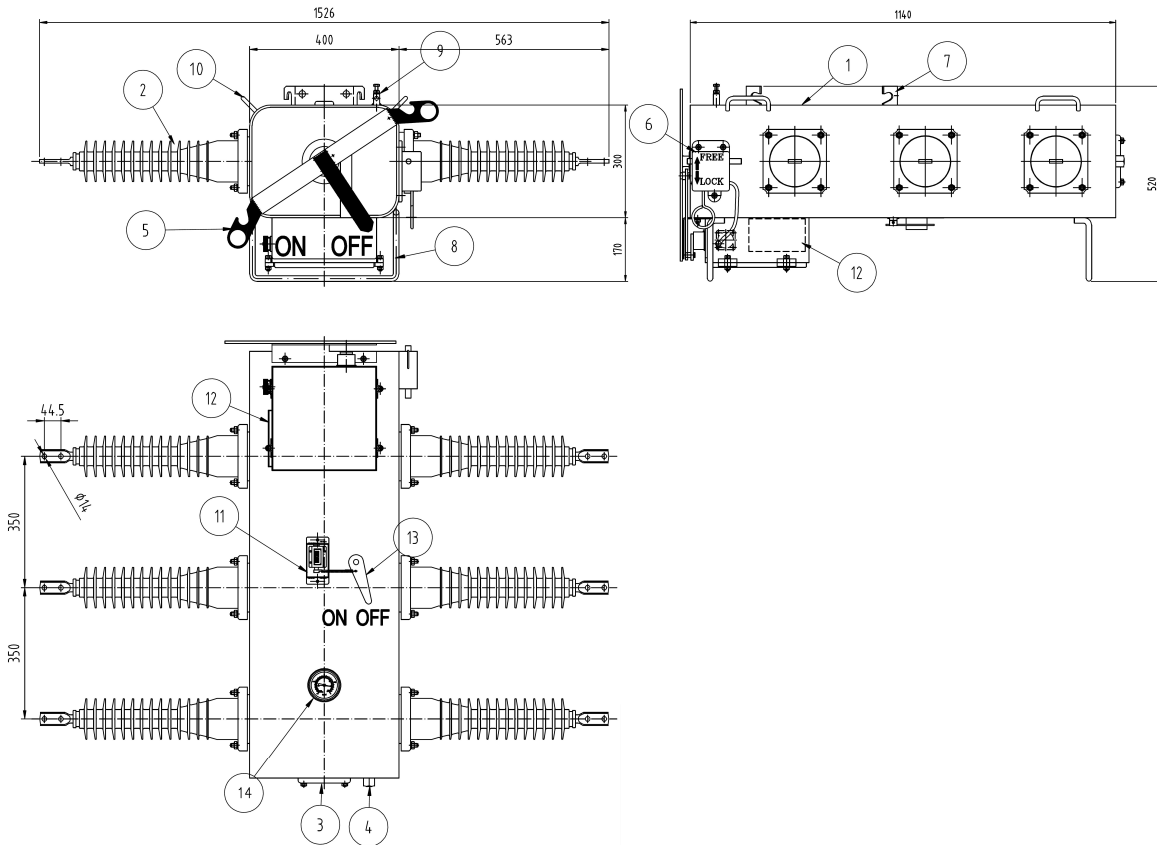

No.	Name of Parts
1	Tank
2	Epoxy Silicone Rubber Bushings
3	Safety bursting membrane
4	Gas filling Valve
5	Operating Handle
6	Manual Locking Device
7	Lifting Lugs
8	Legs
9	Earthing Terminal
10	Mounting hangers
11	Operation counter
12	Name Plate
13	On/Off Indicator
14	Gas pressure Gauge

L6 Control Unit

Overview

The L6 control with built-in RTU function have not only enhanced protection functions like open conductor, high impedance fault isolation, but also can identify and isolate the faulted section and can restore the service with the coordination of backup circuit breaker or VIT recloser without communication system.

It have two(2) setting groups and it can be changed automatically according to the power direction.

The L6 control can achieve the feeder automation with minimum initial investment but in the future it can be integrated to the computer system just through adding a modem.



Functions

■ Main Protection Function

- Fault indication**
 - Phase fault / ground fault
 - Permanent fault / temporary fault
- Open conductor / loss of phase protection
- Phase synchronization failure detection
- Sectionalizer function**
- SEF, HIF protection**
- Voltage-current-time controlled protection coordination(VIT)**
- Inrush current restraint**

■ Measurements

- Magnitude and phase angle of voltages & currents (Fundamental frequency)
- RMS and phase angle of voltages & currents (Fundamental frequency)
- Active, reactive and apparent power for each phase and 3-phase
- Demand current
- Daily maximum current
- Symmetric component
- Power factor
- Frequency
- Phase difference between source and load-side voltage

■ Control

- Manual LBS switch Open / Close at local or remote (SBO operation)
- Interlocking (Gas low, Handle lock, Sync. Fail, Live Load)
- Battery test
- External Trip and Close

■ Switch & Control Status Monitoring

- Contact inputs
 - Switch Open / Closed
 - Gas pressure low
 - External AC power loss
 - Handle status
 - Enclosure door open

-

- Battery status
- Temperature
- Frequency
- Switch operation count

■ Event Recording

- Sequential events record
- Fault events report
- Fault wave form report
- Demand Current
- Daily maximum current

■ Additional Control and Communication Function

- Two(2) selectable setting groups ideal for loop scheme application.
- Hot line tag against unexpected local and remote operation
- Local and remote operation
- IEC60870-5-101 and IEC60870-5-104 protocol for remote communication
- MODBUS local communication for setting, analysis, control, maintenance via PC software

■ Communication Interface

- 2 x RS232C port for local/remote setting and maintenance and SCADA communication
- 1 x Ethernet port
- 1 x Spare Port

Operation

The L6 has five(5) operating modes to achieve best coordination.

■ Customer protection (Watch Dog) mode

- 1 count trip
- Inrush restraint feature
- Overload protection
- DIR SEF protection
- HIF protection
- Pure Open conductor protection
- Under voltage protection (loss of phase protection)

■ Radial sectionalizer mode

The radial sectionalizer mode is the best choice at the end of the radial line.

The operation of radial sectionalizer mode is exactly the same with current, counts controlled sectionalizer.

Max. three(3) sectionalizer can be used according to the numbers of operation to lockout of the backup protective device.

If the backup device is circuit breaker, one or two counts can be used and if the backup device is recloser, one, two, three counts sectionalizer can be coordinated.

But if it is necessary to sectionalize more points, the remaining switches other than one or two sectionalizers, the control should be set to radial normal close mode.

Radial sectionalizer mode has the same features with current, counts controlled sectionalizer but has more functions.

- Directional ground minimum pick up
- Counts one(1), two(2), three(3)
- Counts reset timer in load current condition
- Inrush restraint feature
This feature is activated when the control experience normal current before current cessation to avoid miscounting because of the inrush current during reclosing process of back up equipment. If this feature is activated, the minimum pickup setting raised automatically to the preset multiply during preset restraint time.
- Count restraint feature using current and voltage element
- One(1) count to open feature directly after manual closing
- Open conductor, high impedance fault isolation
- Over-load protection can protect the line from over-current condition up to the locking current(900A).
- V_0/V_1 unbalance voltage protection protects the line from loss of phase, open conductor and ferro-resonance over voltage

■ Radial normal close mode

This operating mode is selected to expand the number of switches in radial line.

The important features are;

- Phase & Ground fault current counting
- Counts reset timer in load current condition
- Close timer
- Load side lockout timer
- **Open conductor, high impedance fault isolation**

Unlike conventional V-T controlled scheme, only the switch experienced the fault will be open after counts, so the restoration is much fast and can give the chance for backup device to clear the temporary fault.

Also the number of switch operation is reduced more than 50% of V-T scheme through fault current tripping and counts block function.

■ Loop normal close mode

If this operating mode is selected, it has more functions than radial normal close mode.

- Loss of voltage lockout feature
- Loss of voltage, fault current counting
- Counts reset timer in load current condition
- Close timer
- Load side lockout timer
- Source side lockout timer
- **Open conductor, high impedance fault isolation**
- Two setting groups according to the power direction

If there is a fault in loop network, the source and load side is isolated already before the normal open switch close, so it can avoid unnecessary outage during normal close switch close into fault condition.

■ Loop normal open mode.

This operating mode has the same function with loop normal close mode, but has more function.

- Normal open source side lockout feature
- Normal open close timer
- Two setting groups according to the power direction
- Automatic mode change from normal open mode to normal close mode when it is closed
- Automatic mode change from normal close mode to normal open mode and lockout when it is open by manually. This lockout state will be reset automatically when there are both side voltages.

Example Illustration of sequential coordination on the loop mode.

The following is achieved by the coordination between VIT Recloser and VIT LBS.

■ Line Diagram and Setting

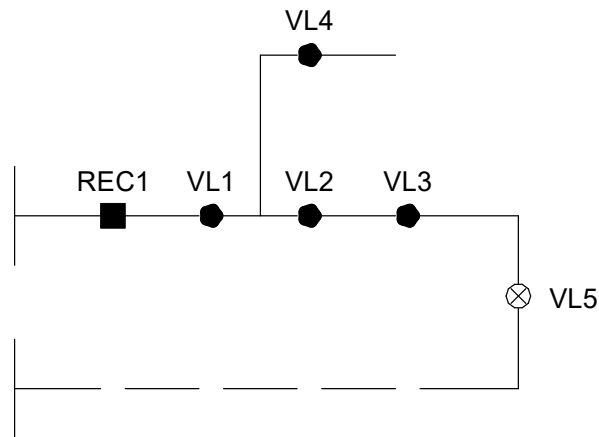

- REC1 : 4trips, 3reclosing /Reclosing interval 1st 2sec, 2nd 5sec, 3rd 5sec
- VL1 : Count = 2 / X Time = 2sec. / XL Time = 20sec.
- VL2 : Count = 2 / X Time = 4sec. / XL Time = 20sec.
- VL3 : Count = 2 / X Time = 2sec. / XL Time = 20sec.
- VL4 : Count = 2 / X Time = 2sec. / Current Mode = Enable

■ Sequential Operation

Sequence	Status	Description
1	<p>The diagram shows the same circuit as above, but with a fault symbol (a lightning bolt) at VL3. A ground symbol is also present below VL3. The status of components is: REC1 (black square), VL1 (black circle), VL2 (black circle), VL3 (black circle with lightning bolt), VL4 (black circle), and VL5 (circle with an X).</p>	Fault Initiation
2	<p>The diagram shows the same circuit as above, but REC1 is now a white square, indicating it has tripped. The status of components is: REC1 (white square), VL1 (black circle), VL2 (black circle), VL3 (black circle), VL4 (black circle), and VL5 (circle with an X).</p>	REC1 1 st trip VL1, VL2, VL3 voltage count VL4 no count VL5 voltage count

<p>3</p>		<p>REC1 1st reclosing</p>
<p>4</p>		<p>REC1 2nd trip VL1, VL2, VL3 voltage count VL4 no count VL5 voltage count</p>
<p>5</p>		<p>VL1, VL2, VL3 open</p>
<p>6</p>		<p>REC1 2nd reclosing after 5sec. VL1 Close Time start</p>
<p>7</p>		<p>VL1 close VL2 Close Time start</p>

<p>8</p>		<p>VL2 close after 4sec. Fault Re-generation VL3 open lockout timer start,</p>
<p>9</p>		<p>REC1 3rd trip</p>
<p>10</p>		<p>VL2 open lockout after 0.7sec, VL3 Lockout</p>
<p>11</p>		<p>REC1 3rd reclose after 5sec.</p>
<p>12</p>		<p>VL5 close (Change the mode from normal open to normal close)</p>

Pole Top Installation – Automatic Type

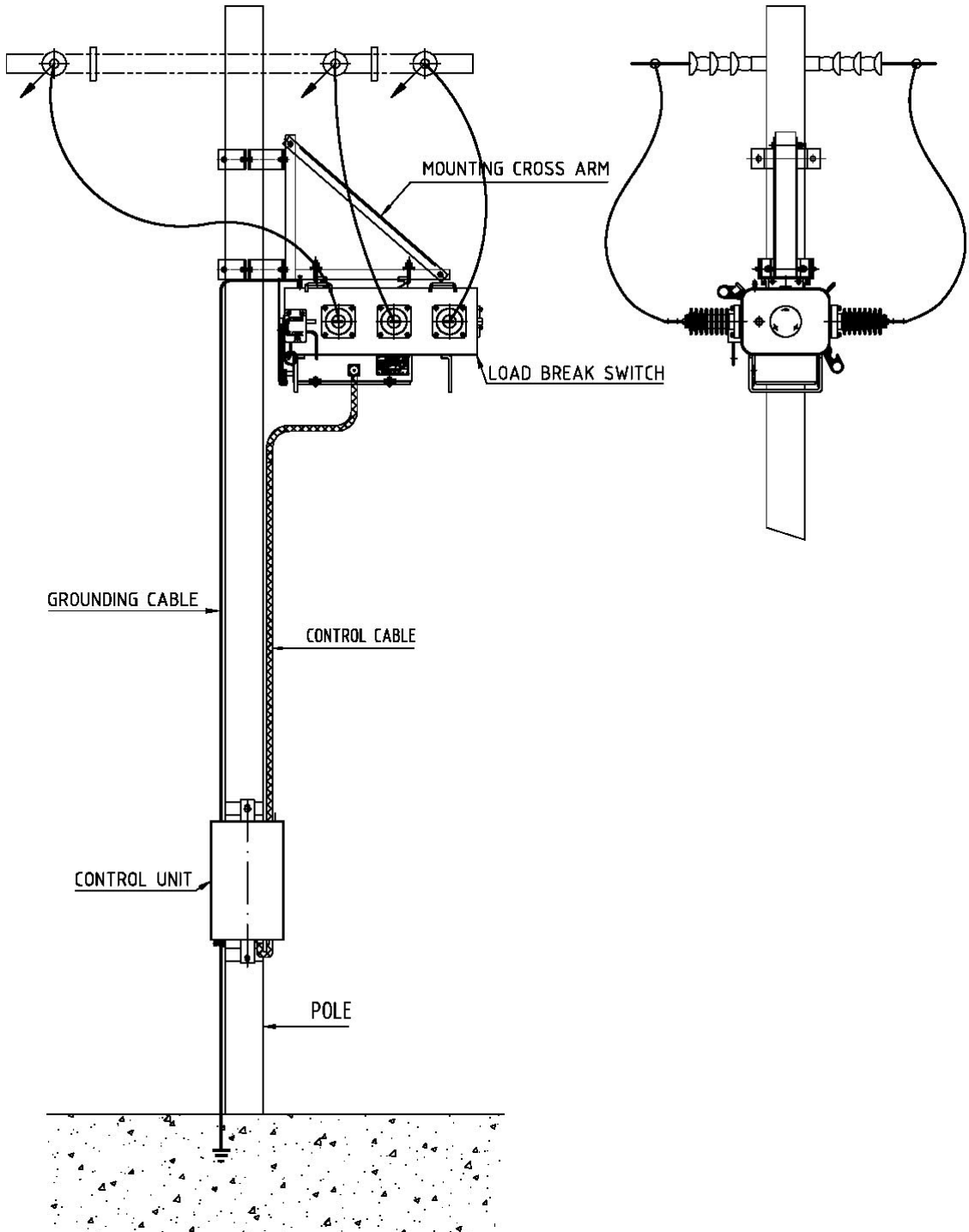

Worldwide Sales Location



Headquarters in Korea

Shinsung Industrial Electric Co., Ltd

190-4 Soohyang-ri, Sunghwan-eup, Seobuk-gu,
Cheonan-si, Chungcheongnam-do, Republic of Korea

Postal(Zip) Code: 331-802

Tel: +82-41-582-5029 Fax: +82-41-582-8752

E-mail: shinsungglobal@empas.com / intlbiz@ssiec.co.kr

Website: <http://www.ssiec.co.kr>